

Lattice Quantum Chromodynamics Project

SciDAC-4

Robert Edwards



LQCD ASCR/NP SciDAC-4

Computing the Properties of Matter with Leadership Computing Resources

PI: Robert Edwards (JLab)

Co-PIs: Will Detmold (MIT), Balint Joo (JLab), Swagato Mukherjee (BNL)

Senior Investigators:

Andrei Alexandru (GWU)

Saman Amarasinghe (MIT)

Alexei Bazavov (MSU)

Kate Clark (NVIDIA)

Rob Fowler (UNC)

Dhiraj Kalamkar (Intel)

Xu Liu (W&M Computer Sci)

Kostas Orginos (W&M Phys)

Sergey Panitkin (BNL)

Andrew Pochinsky (MIT)

Kenneth Roche (PNNL)

Martin Savage (UW)

Frank Winter (JLab)

Boram Yoon (LANL)

Team members

Long term collaborations with ASCR supported community and Industry

- Gauge generation (co-PI: Balint Joo)
 - **Balint Joo** - Sparse linear system solvers on emerging LCF-s (Cori, Summit, NERSC-9)
 - **Siva Rajamanickam** - KokkosKernels 
 - **Boram Yoon** - Symplectic PDE Integrators
 - **Kate Clark (NVIDIA)** - comms reduced solvers, Integrators
 - **Kostas Orginos** - 1 flavor methods
 - **Xu Liu** - Memory optimizations (QPerf and HPC Toolkit)
 - **Robert Fowler** - QUARC/DSL interface to Clang/LLVM - automatic code generation
- Correlation functions/contractions (co-PI: Will Detmold)
 - **Saman Amarasinghe** - (TACO) code generation, auto-tuning for contractions (& gauge gen)
 - **Andrew Pochinsky** - Halide for QCD
 - **Kenneth Roche** - workflow, data reductions/sparsification/SVD approximations for contractions
 - **Andrei Alexandrou** - overlap analysis campaigns for KNL-s
- Thermodynamics and Workflow (co-PI: Swagato Mukherjee)
 - **Sergey Panitkin**: PanDA/ATLAS workflow for LCF systems, multi-site campaigns, scheduling, file transfers & data integrity
 - **Alexei Bazavov** - transport coefficients

LQCD/NP Science & connection to Expt.

QCD stands for *Quantum Chromo-Dynamics*

the theory that describes the interactions of quarks and gluons that constitute the matter of the visible universe

- What observable states does QCD allow?
 - What is the role of the gluons? Is there exotic matter?
 - Focus of GlueX@JLab experiment
- How do nucleons (protons & neutrons) arise?
 - How are quarks & gluons distributed in a proton or neutron?
 - Focus of 12 GeV@JLab, RHIC-spin@BNL and future EIC
- QCD must predict properties of light nuclei
 - Nuclear reaction properties. Are there new fundamental symmetries?
 - FRIB@Mich. State. will investigate nuclear structure and interactions
- How does QCD behave under extreme temperatures & pressures such as in supernovae or shortly after Big-Bang?
 - Studied in RHIC@BNL & ALICE@LHC

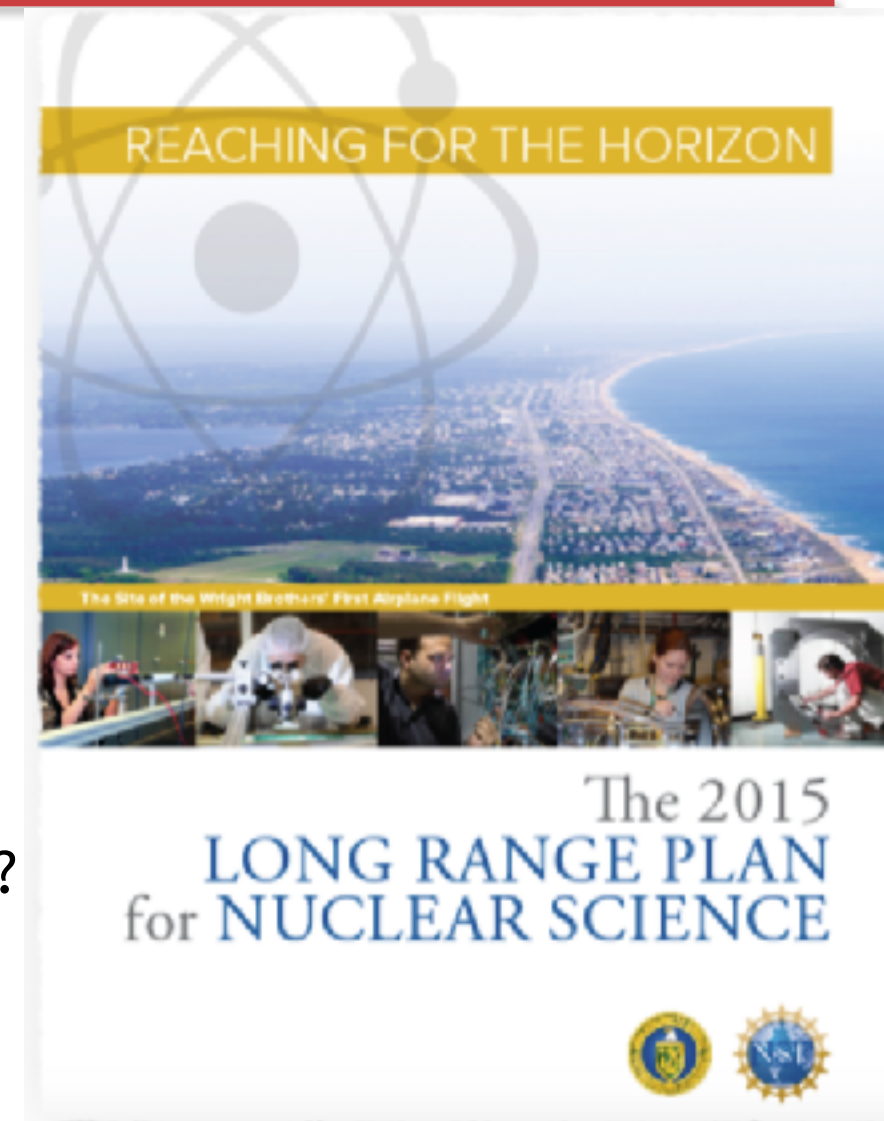

http://science.energy.gov/~media/np/nsac/pdf/2015LRP/2015_LRPNS_091815.pdf

Lattice QCD & the excited hadron spectrum

LQCD SciDAC project has pioneered novel techniques in lattice QCD

Light quark meson + “exotics” & “hybrids” spectrum

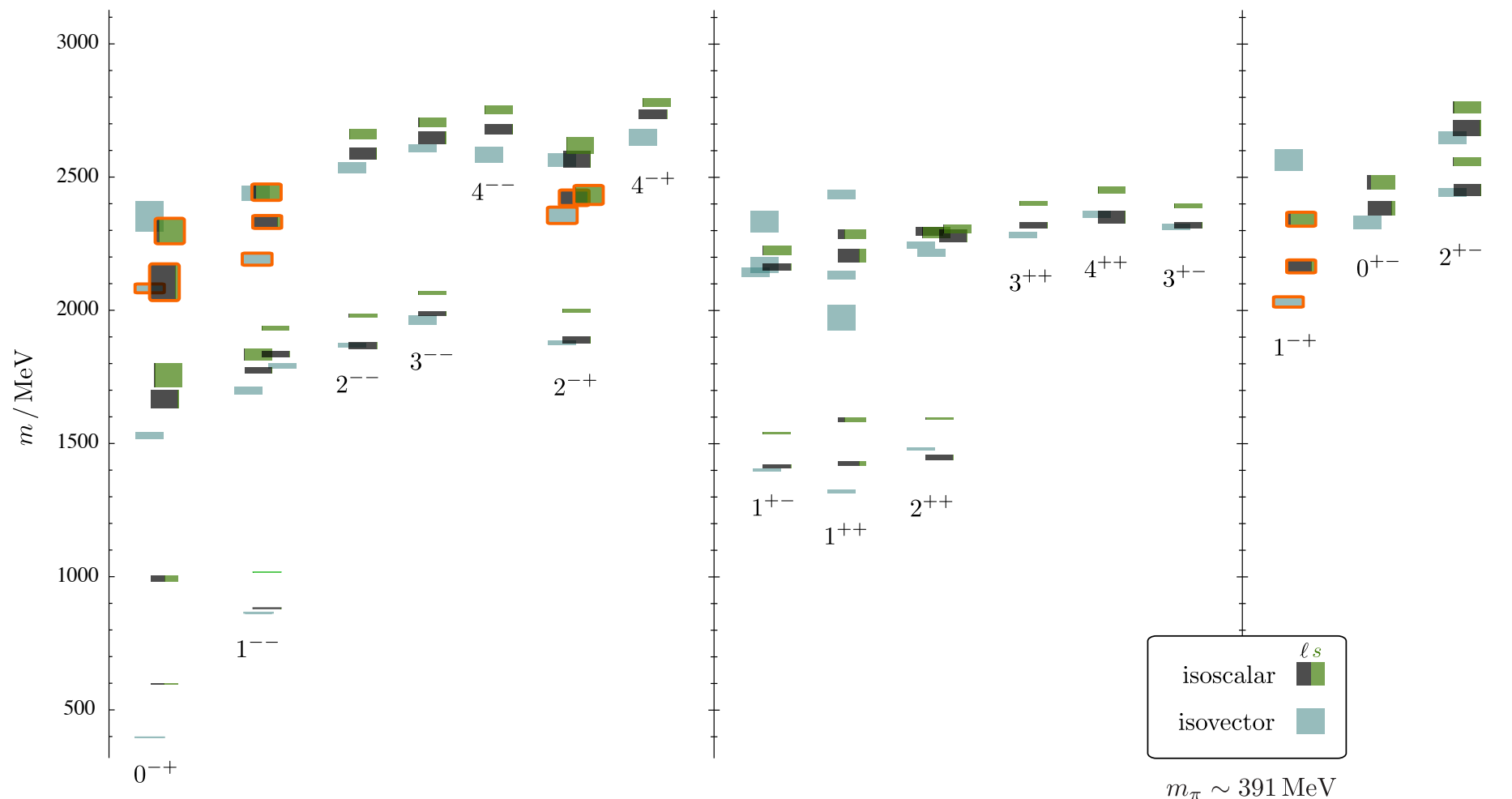

‘Toward the excited isoscalar meson spectrum from lattice QCD’
 PRD 88 094505 (2013)

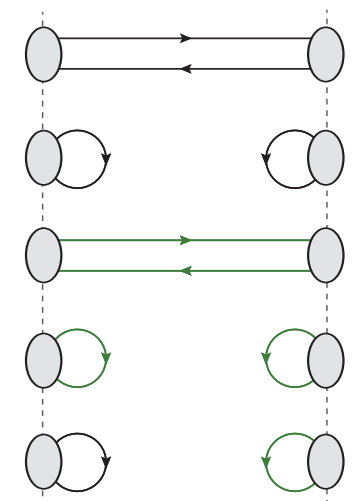

high precision calculation of disconnected diagrams

clear indication of a spectrum of hybrid mesons



Hadron Spectroscopy - role of the glue

Focus of GlueX & CLAS12 @ JLab & COMPASS, LHCb @ CERN, BES @ Beijing

Light quark meson + "exotics" & "hybrids" spectrum

Exotics

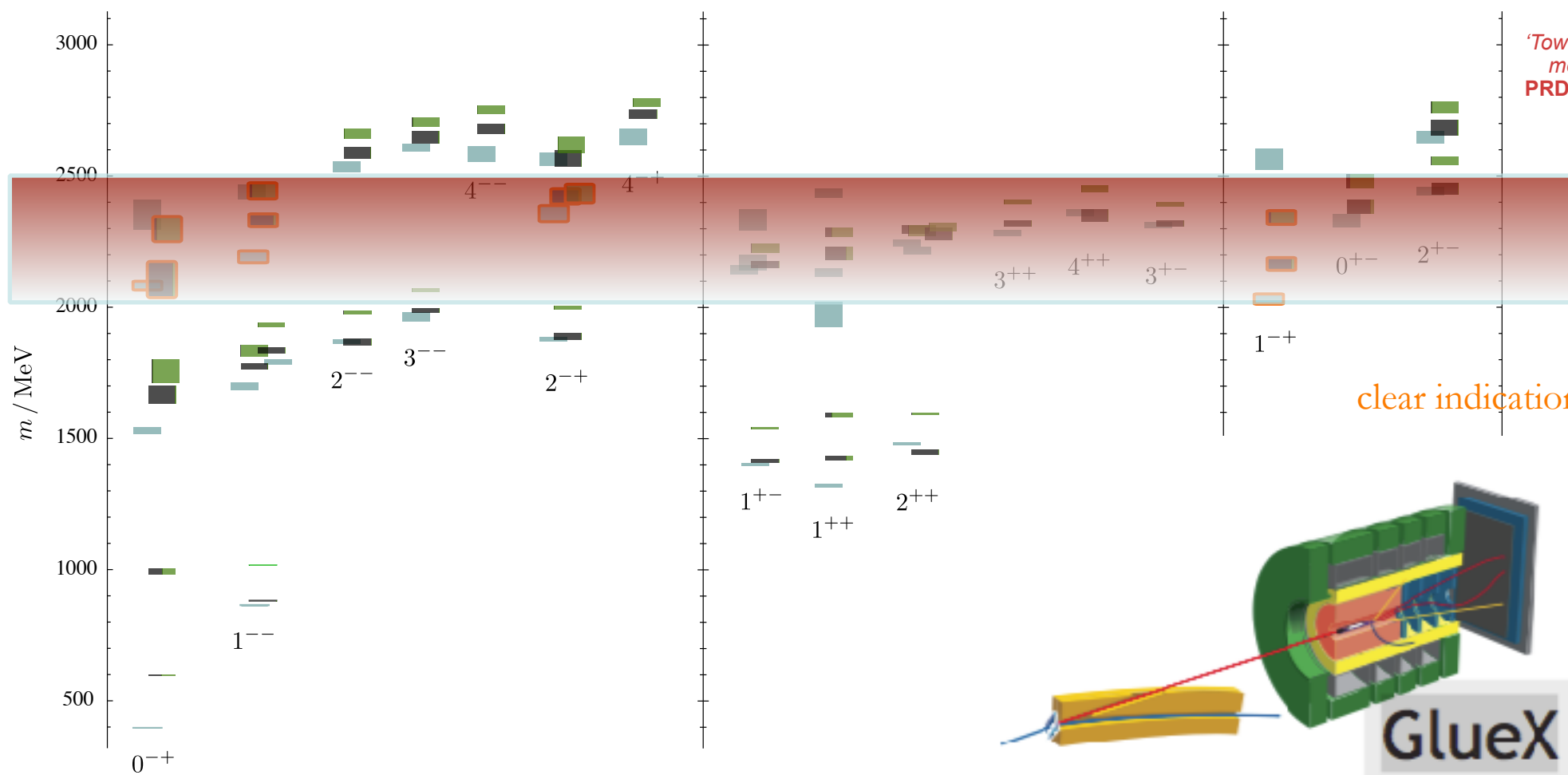

'Toward the excited isoscalar meson spectrum from lattice QCD'
PRD 88 094505 (2013)

clear indication of a spectrum of hybrid mesons

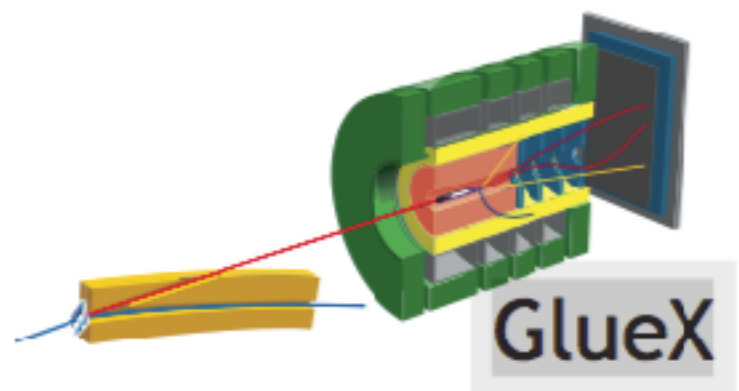

Pattern of states suggest gluonic excitations

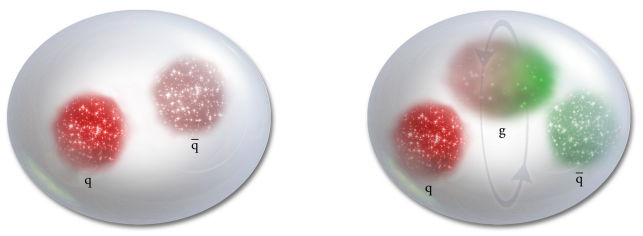

➔ Need to know decay modes and rates to compare to expt.

First calculations of decay modes

Light quark meson + "exotics" & "hybrids" spectrum

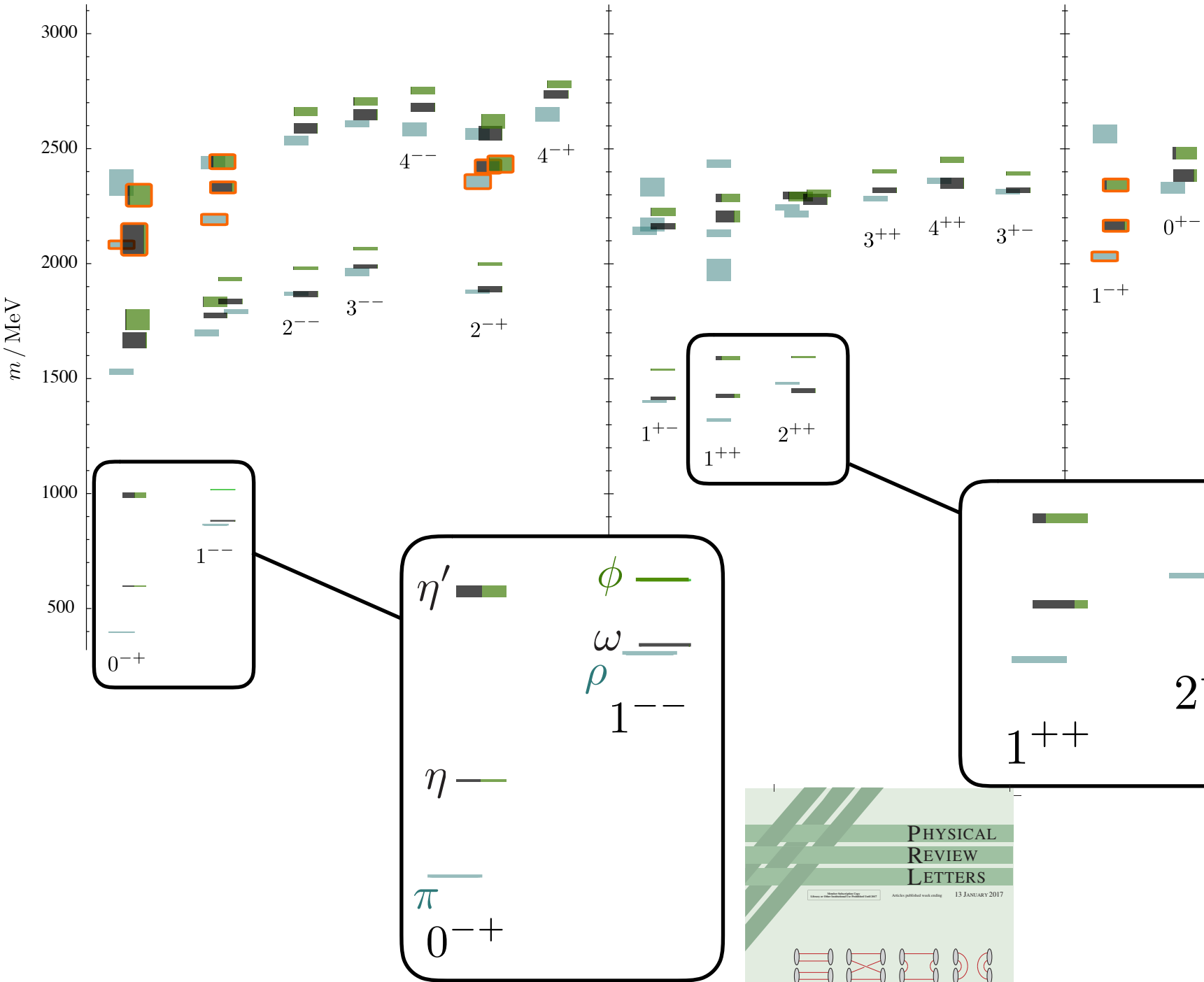

Exotic



*flavor tagging
by decays*

PDG

- $f_2(1525) \rightarrow K\bar{K} \text{ 89\%}$
- $f_2(1270) \rightarrow \pi\pi \text{ 84\%}$

Used as motivation in
GlueX detector upgrade proposal

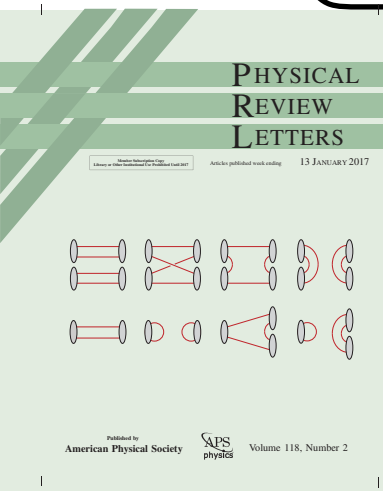

HadSpec: Phys.Rev.D97 (2018);
Phys.Rev.Lett.118 (2017)

Proton structure

- Proton has intrinsic spin $J = 1/2$
- How is this distributed amongst the constituents
- “Proton spin crisis”(1988): spin of quarks accounts $\sim 1/8$?
- Disentangling this had take many years

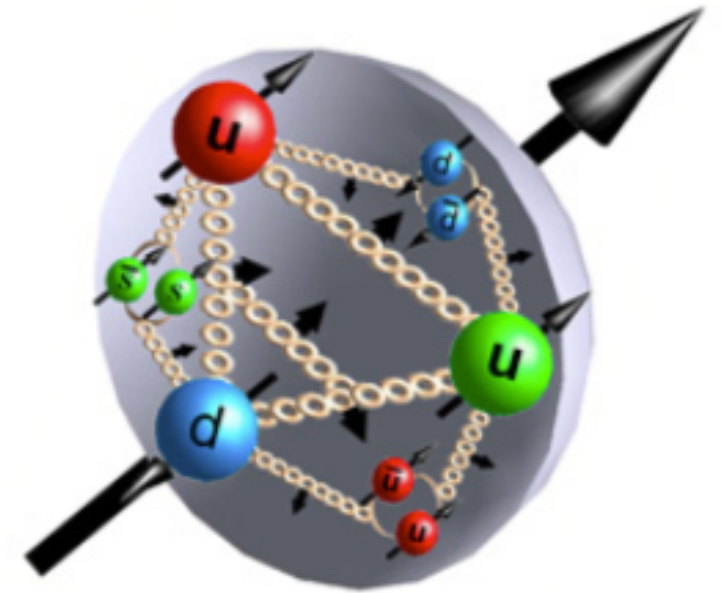

Proton structure

- Proton has intrinsic spin $J = 1/2$
- How is this distributed amongst the constituents
- “Proton spin crisis”(1988): spin of quarks accounts $\sim 1/8?$

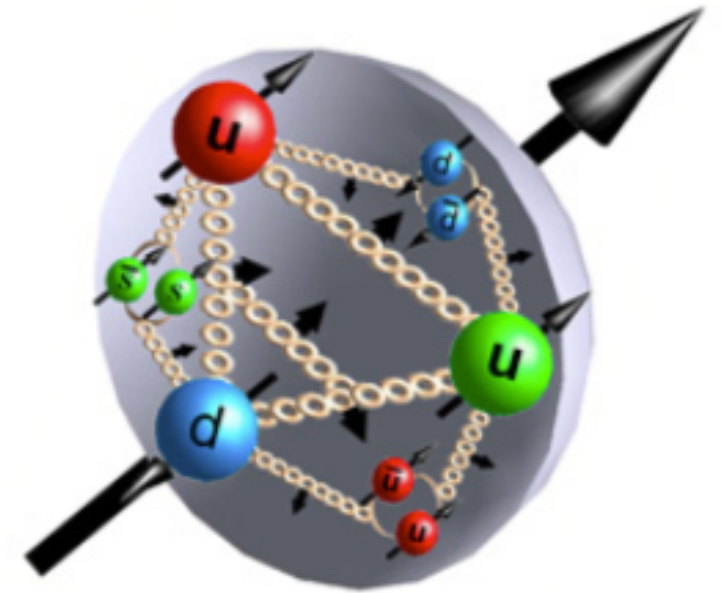

Spin is 1/2 !

First direct calculations
[caveats - only 2 dynamical flavors]

Improving under SciDAC-4

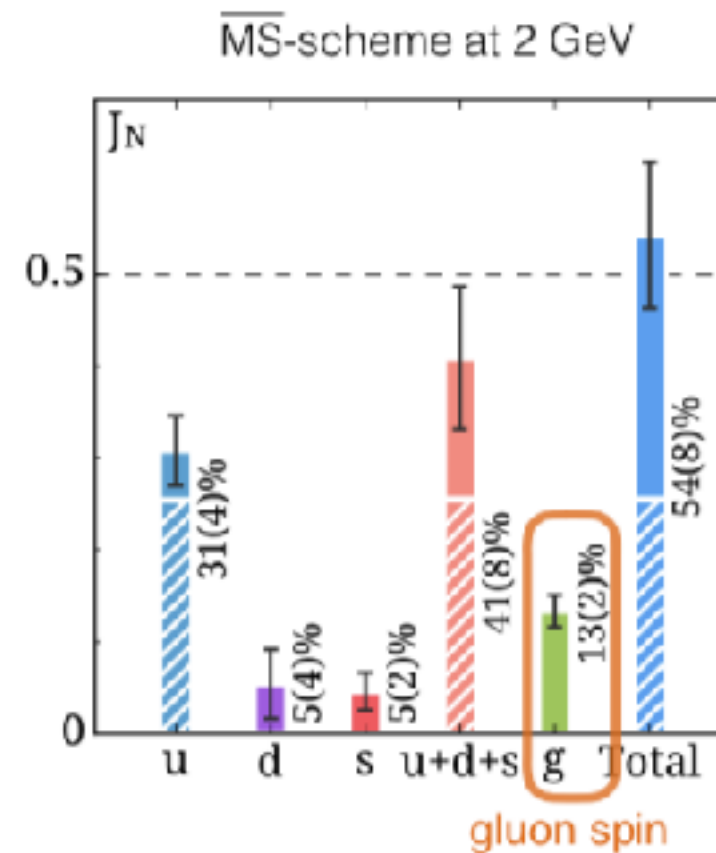

Hashed: connected/ Solid: disconnected

ETMC: Phys.Rev.Lett.119 (2018)

Nuclei

- NPLQCD: interactions of nuclei
- $np \rightarrow d\gamma$ neutron capture [PRL 2016]
- $pp \rightarrow de\nu$ fusion process [PRL 2017]
 - starts the solar fusion cycle
 - difficult to access in expt.
 - first LQCD calc. - competitive to extractions
- Coupling to scalar currents [dark matter] [PRL 2018]
 - significant nuclear effects

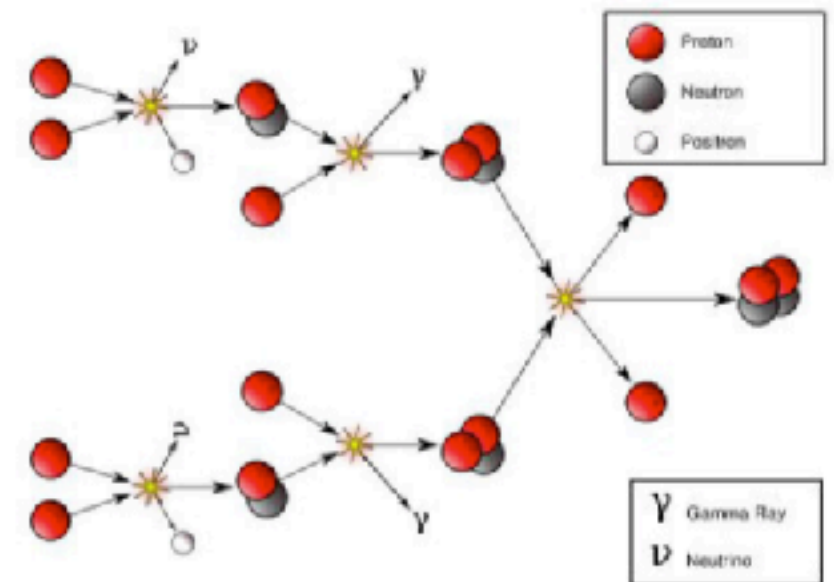

Hot-Dense matter

properties of quark gluon plasma (QGP)

the big questions ...

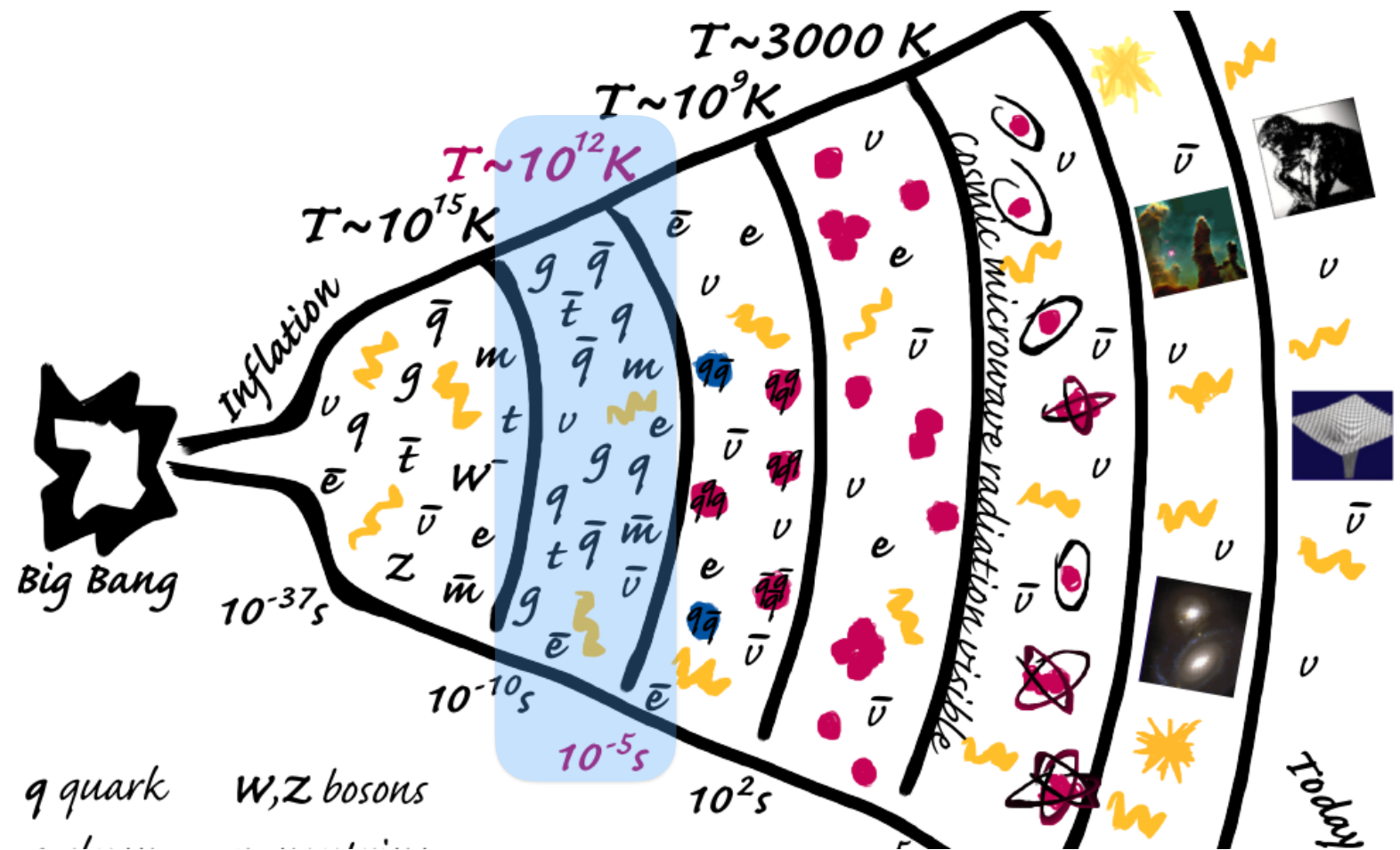

characterize the matter that existed
~ micro-seconds after the Big Bang

Hot-Dense matter

properties of strongly interacting matter

the big questions ...

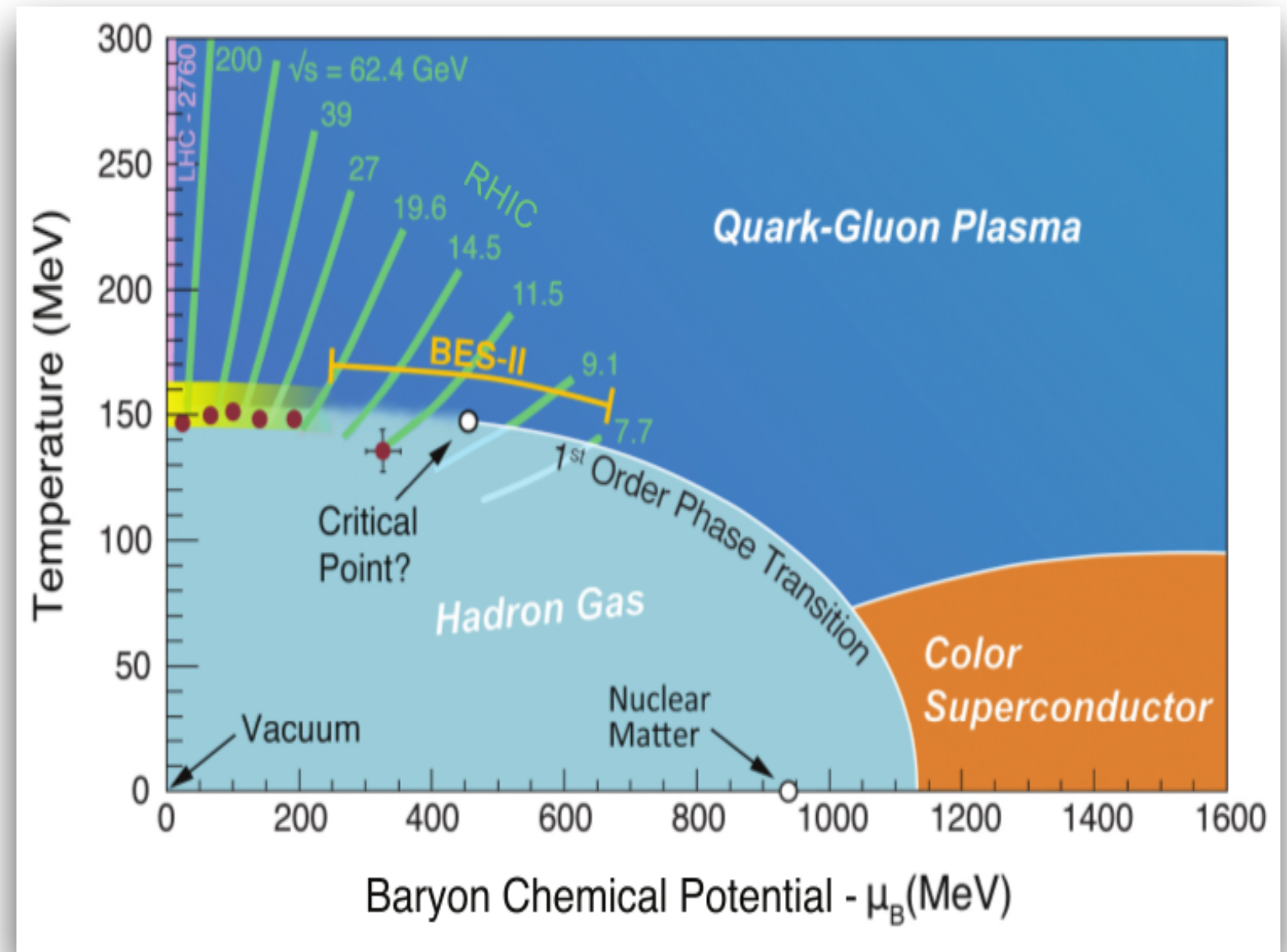
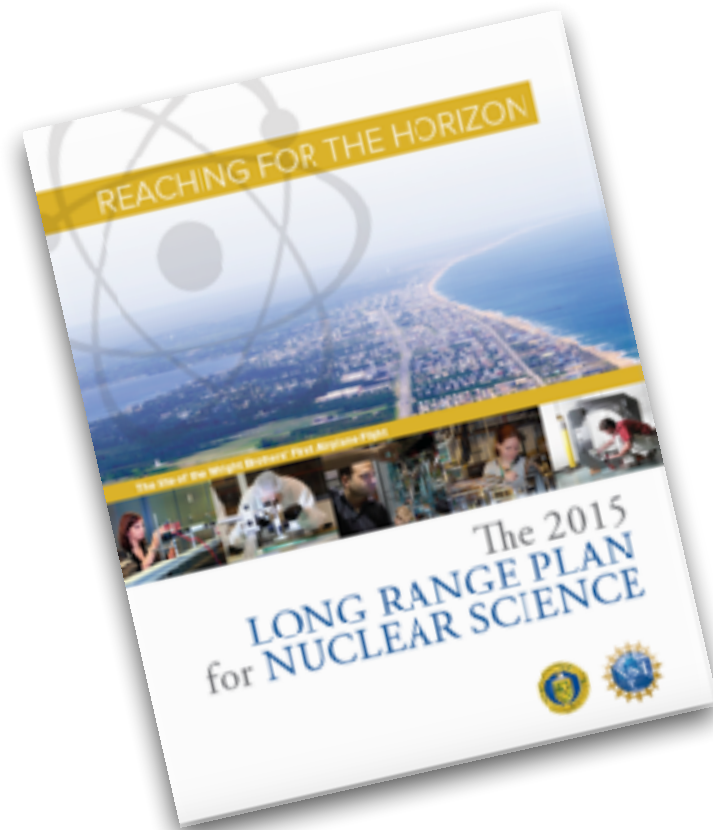

- varying temperatures and densities

Hot-Dense matter - next gen. expt. at BNL

Beam Energy Scan-II @ RHIC



2019-2021

Phase diagram? Critical point?

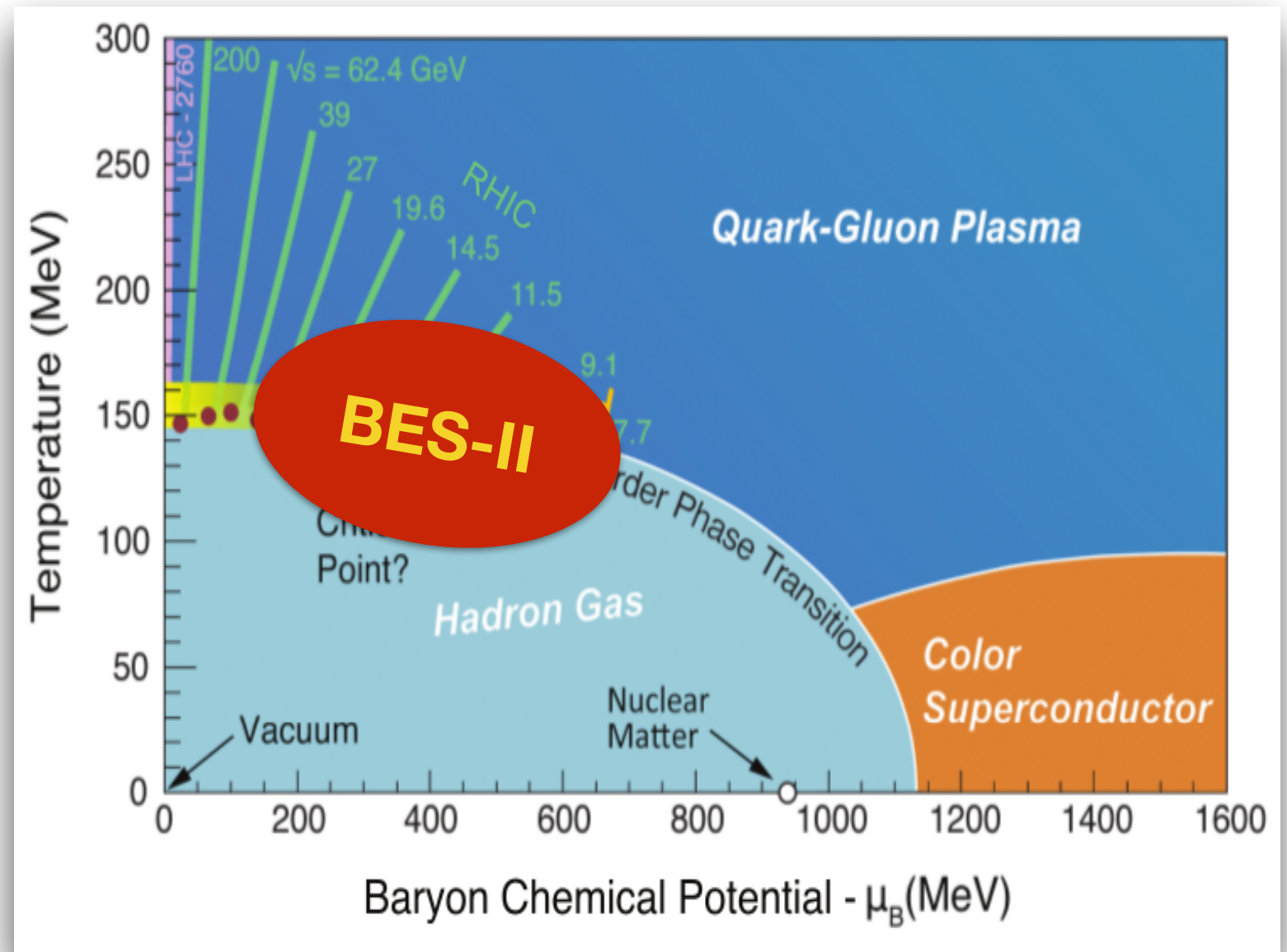

Computational Requirements

Gauge generation

- Leadership level
- Strong scaling



Strong scaling limited

- Comms/compute less balanced in recent machines
- Latency in comms important
- Require comms reduced linear solvers
- 1-flavor solvers

Symplectic PDE integrators

Data-parallel code gen. with comms

Analysis

- Throughput level
- $O(1M)$ RHS-s/cfg



Throughput challenge

- Solvers still important
- Large problems / node -> minimize memory traffic
- Job coordination -> Grid based



Contractions

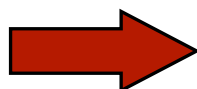

Correlators

- $O(1M)$ /cfg

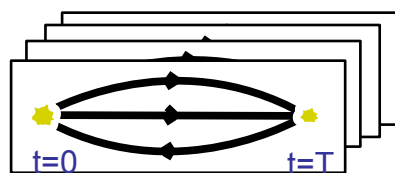

“Workflow” challenge

- Combinatorics -> improved graph theoretic methods
- Code generation for (sparse?) tensor contractions
- Job coordination -> Grid based

How to produce gauge fields?

- Hamilton's equations - 1st order coupled differential eqns.
- Each integration step: sparse matrix solution
- Strong scaling challenge
- **Bummer!**

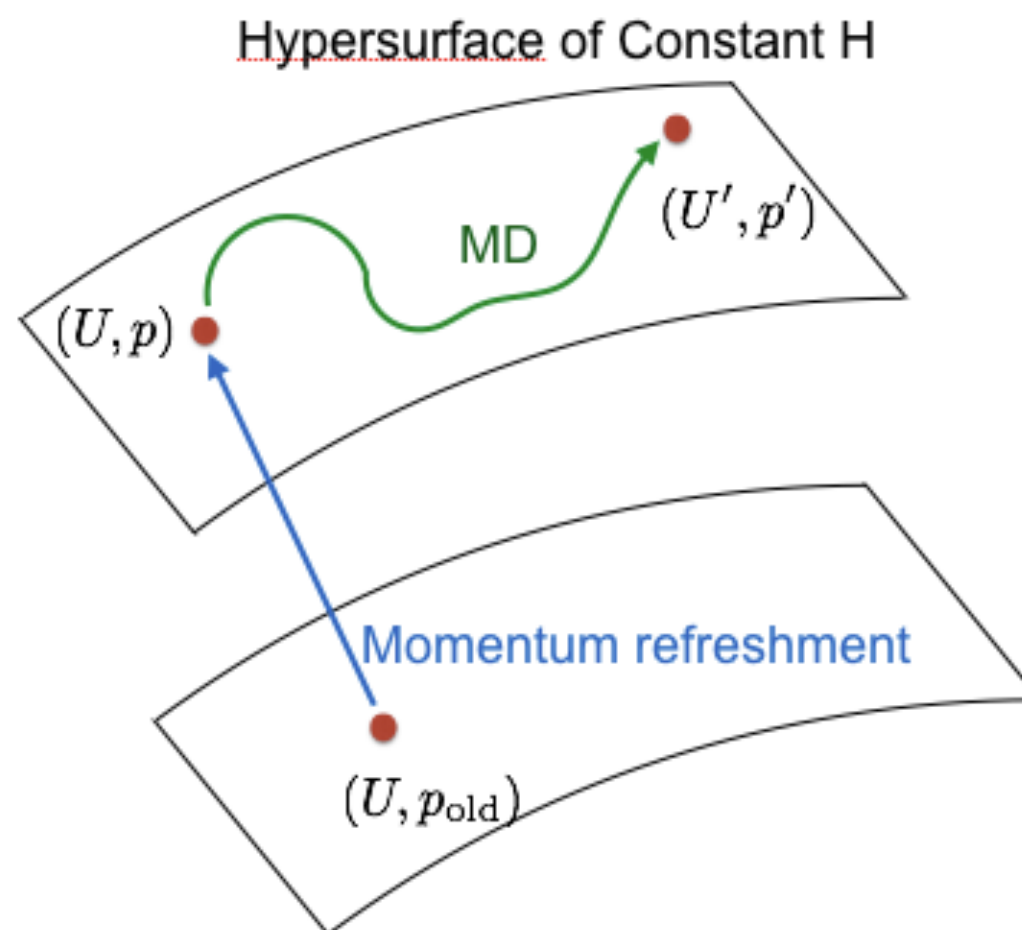

How to produce gauge fields?

- Hamilton's equations - 1st order coupled differential eqns.
- Each integration step: sparse matrix solution
- Strong scaling challenge
- **Bummer!**
 - Must be "reversible"

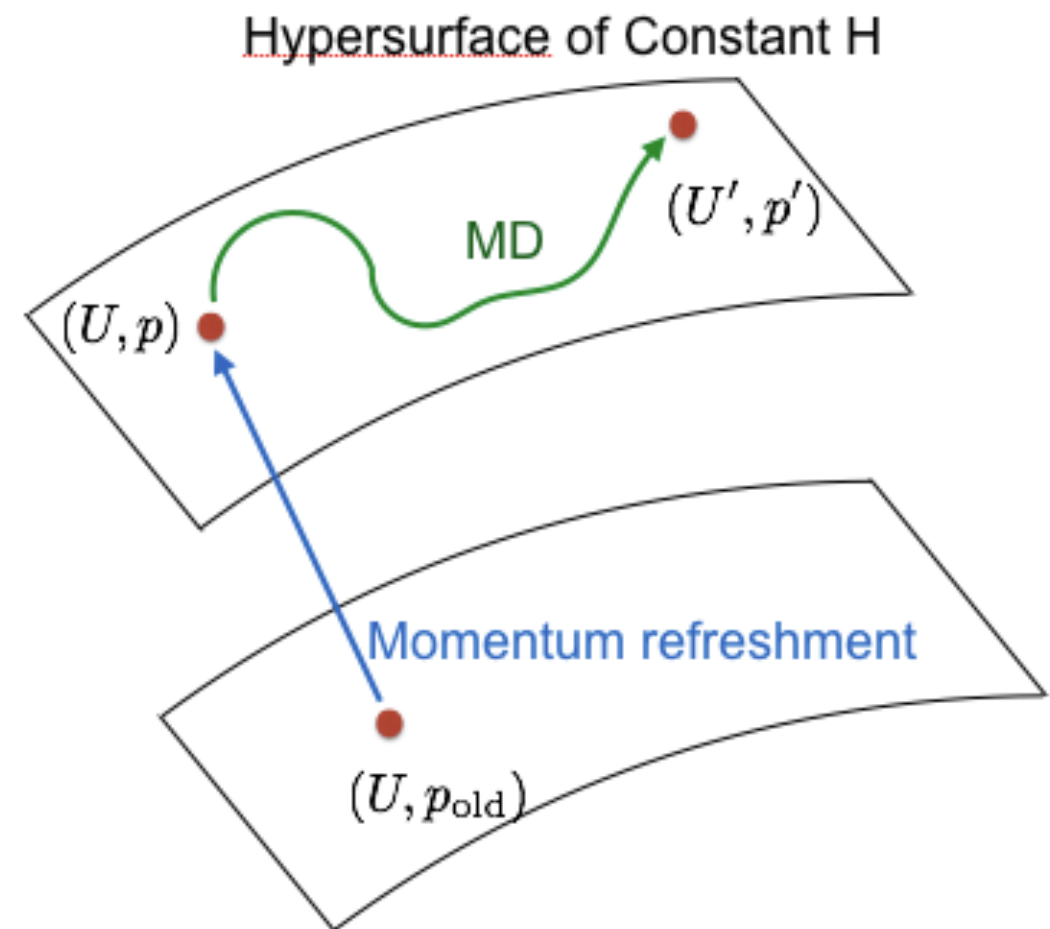

How to produce gauge fields?

- Hamilton's equations - 1st order coupled differential eqns.
- Each integration step: sparse matrix solution
- Strong scaling challenge
- **Bummer!**
 - Must be “reversible”
 - No adaptive time steps

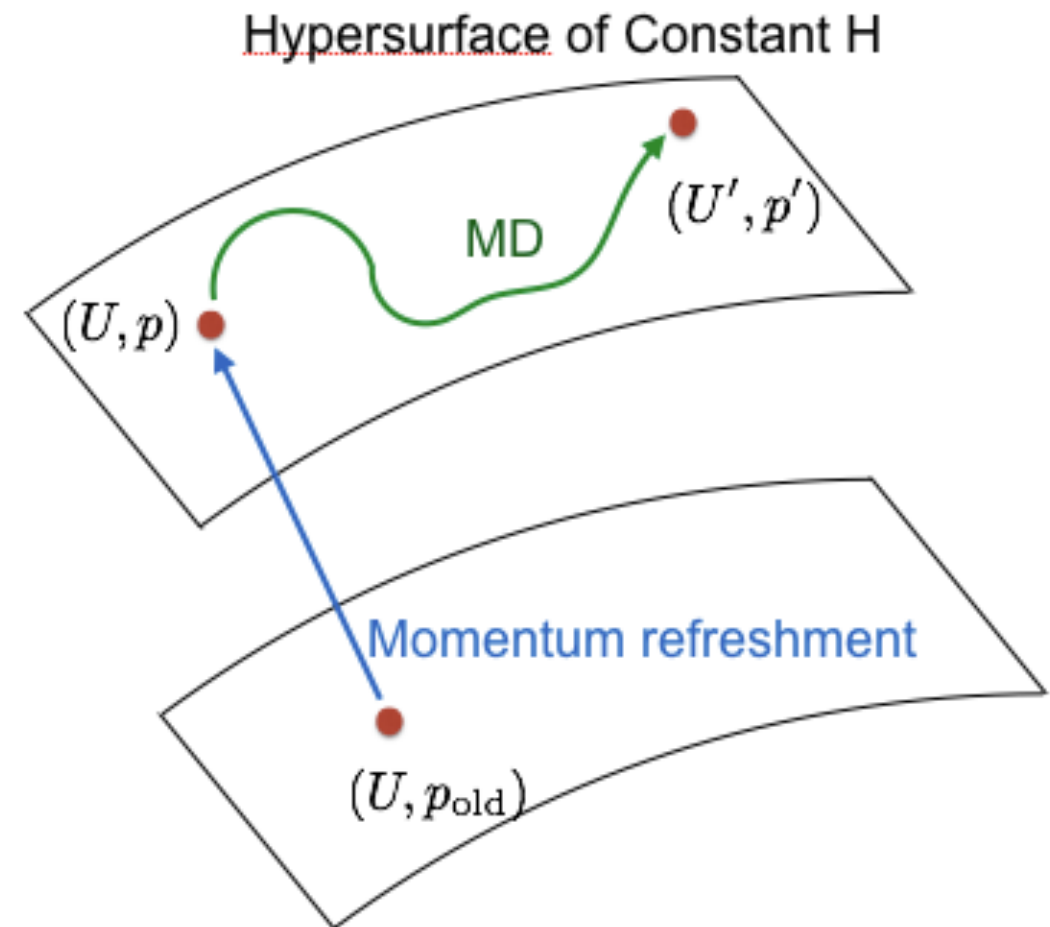

Accelerating QCD gauge generation on GPUs

Collaboration involving ASCR support and Industry partners

[See poster by Balint Joo]

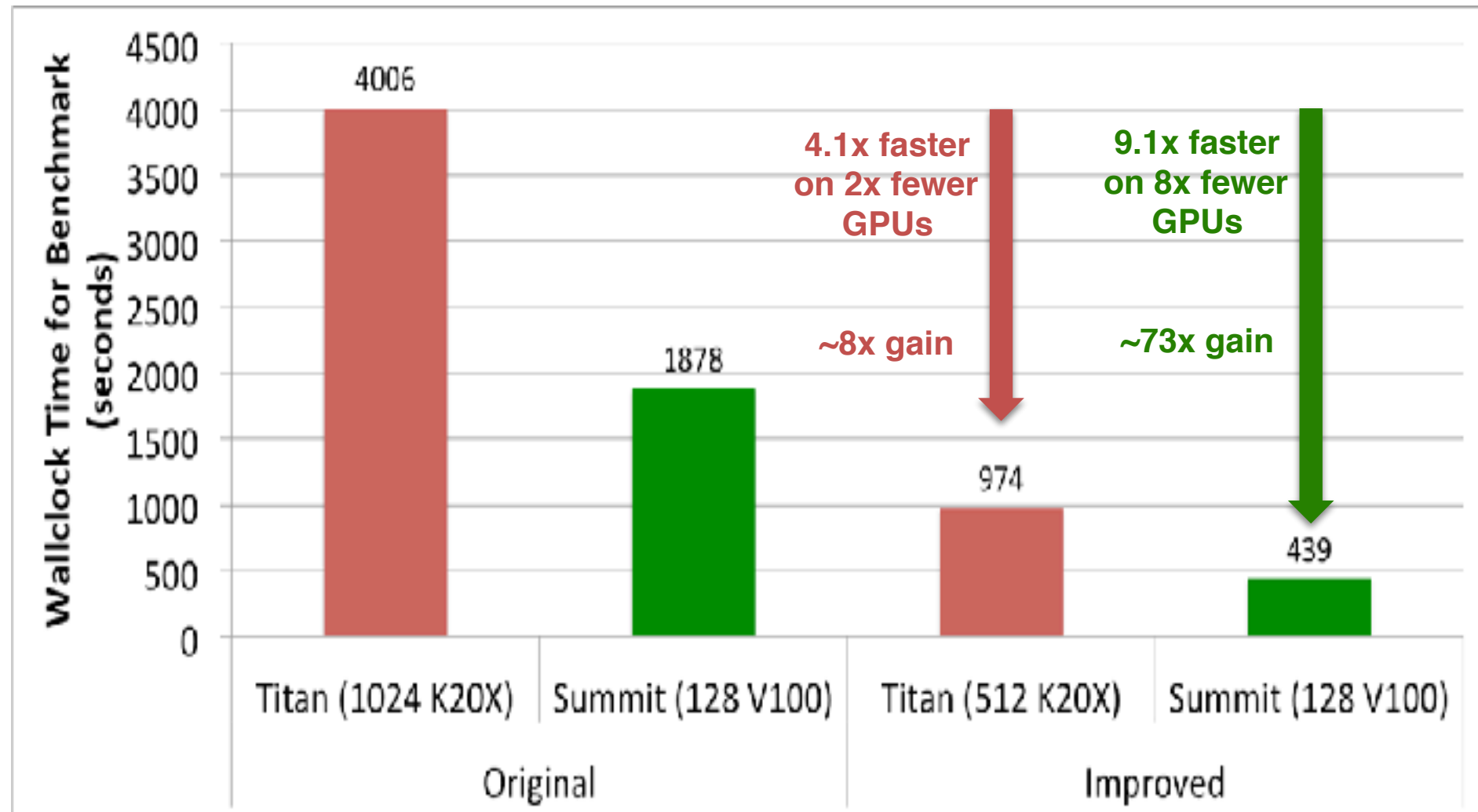
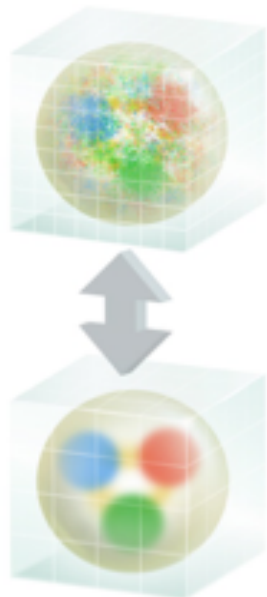
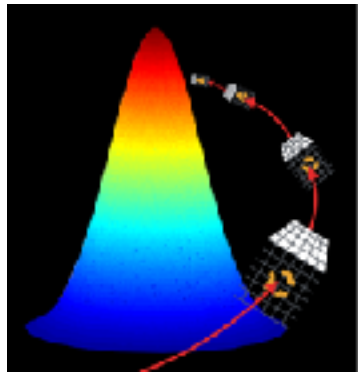

- ~9x wallclock speed-up on Summit using 8x fewer GPUs than Titan:
~73x improvement in computational efficiency
- Allows previously unaffordable calculations

To be OLCF highlight

QUARC framework

ASCR support at Univ. North Carolina

- Alternative to “metal” programming
- C++14 and LLVM-based EDSL framework
- High-level array expressions (METL)
- *QOPT*: Domain-specific compiler
- *Automated code generation*
 - Data layout transformations for SIMD vectorization
 - *Vector folding as in QPhiX, GRID*
 - MPI partitioning, communication, and compute overlapping
 - *Using polyhedral analysis*
 - High-level optimizations
 - *Loop fusion, e.g., multi-RHS*

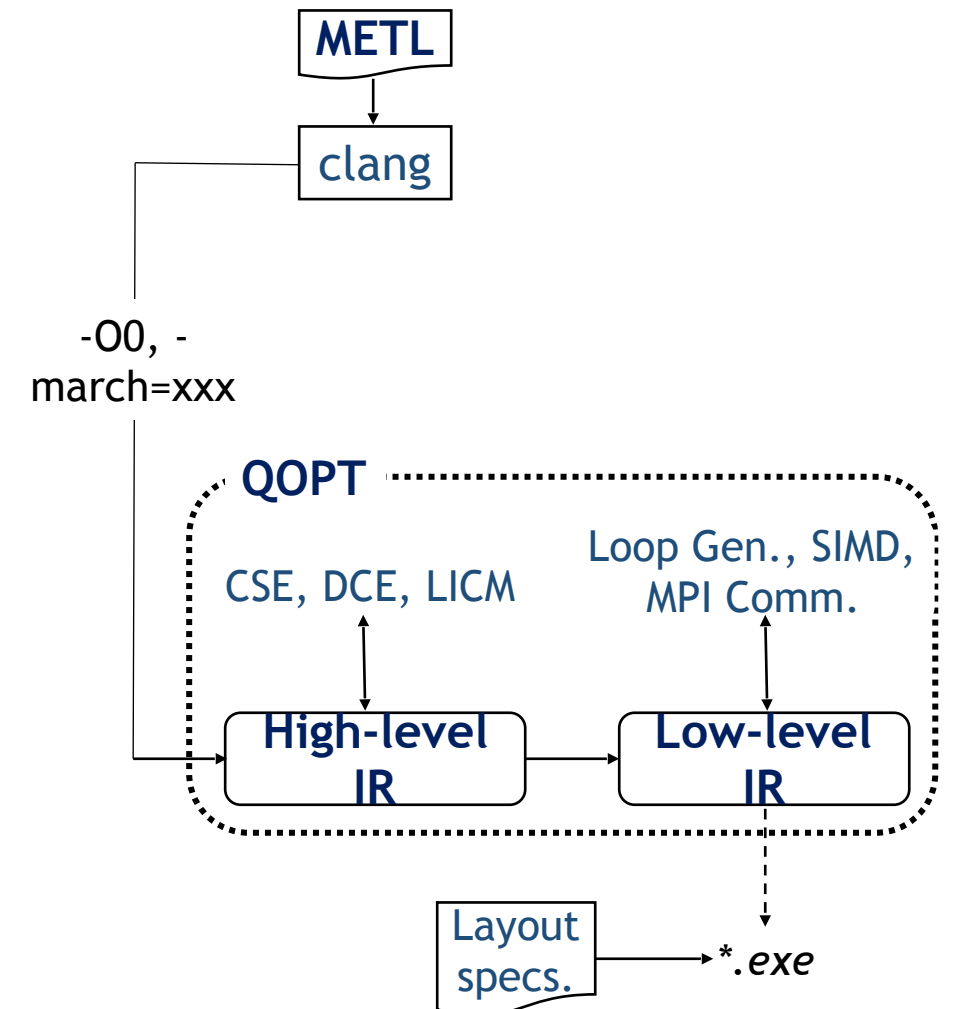

QUARC performance

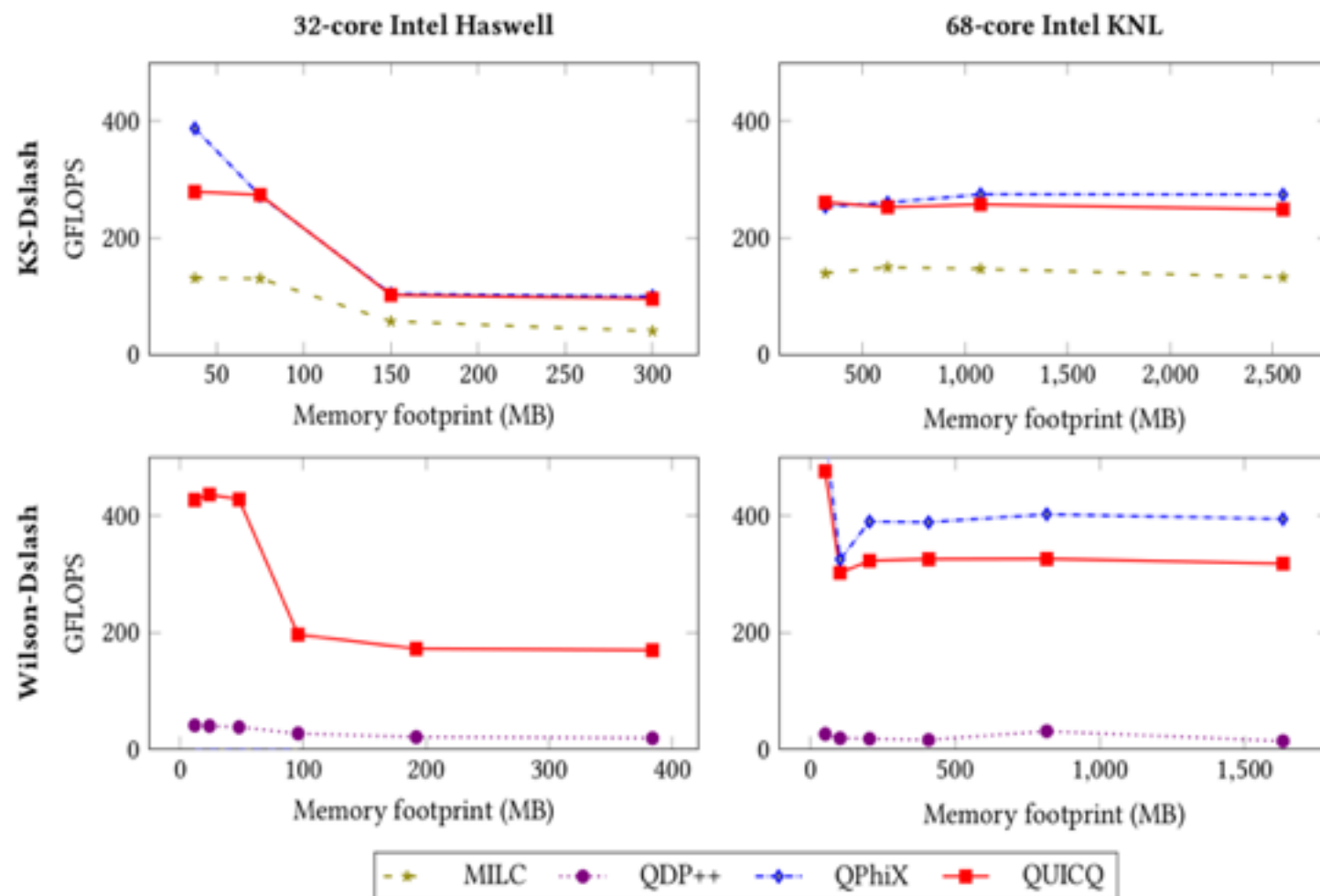

- QUICQ is a prototype EDSL using QUARC
- 10x performance gain over QDP++ (Wilson Dslash)
- 2x performance gain over MILC (KS-Dslash)
- Within 15% of QPhiX on KNL (thread co-location issue)

Next: Improved “workflow”

Gauge generation

- Leadership level
- Strong scaling



Strong scaling limited

- Comms/compute less balanced in recent machines
- Latency in comms important
- Require comms reduced linear solvers
- 1-flavor solvers

Symplectic PDE integrators

Data-parallel code gen. with comms

Analysis

- Throughput level
- $O(1M)$ RHS-s/cfg



Throughput challenge

- Solvers still important
- Large problems / node -> minimize memory traffic
- Job coordination -> Grid based

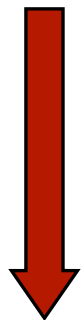

Contractions

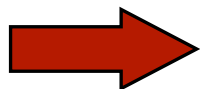

Correlators

- $O(1M)$ /cfg

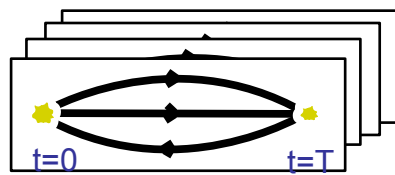

“Workflow” challenge

- Combinatorics -> improved graph theoretic methods
- Code generation for (sparse?) tensor contractions
- Job coordination -> Grid based

PanDA Work Management System



- Developed for ATLAS expt. @ CERN LHC
- Currently processing 1M jobs/day for ATLAS. In use on Titan
- SciDAC-4: “Harvester” - new resource-facing service to Grids, clusters & clouds
- HEP/NP/ASCR partnership [See poster by Sergey Panitkin]

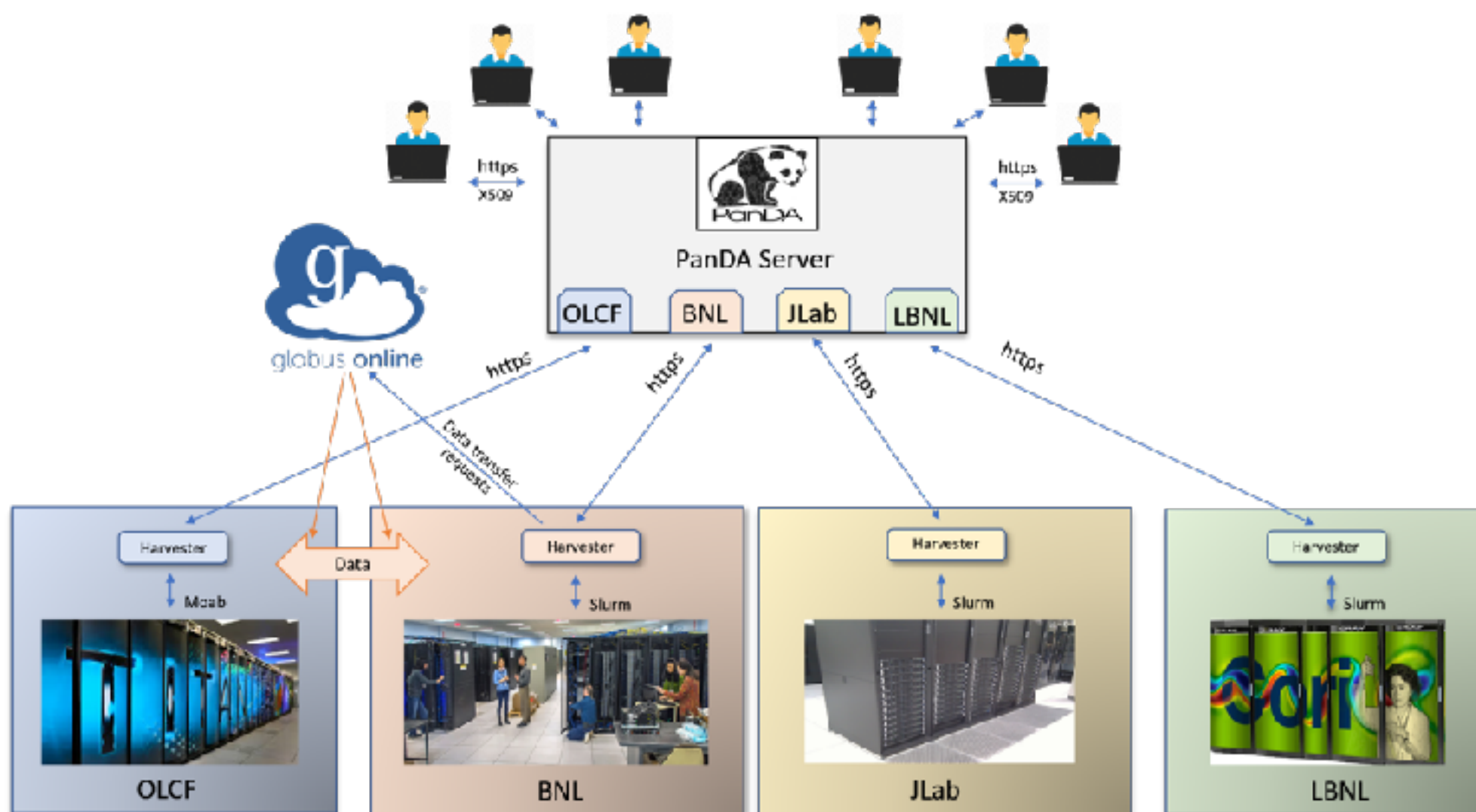

Reducing contraction/correlator costs

Gauge generation

- Leadership level
- Strong scaling



Strong scaling limited

- Comms/compute less balanced in recent machines
- Latency in comms important
- Require comms reduced linear solvers
- 1-flavor solvers

Symplectic PDE integrators

Data-parallel code gen. with comms

Analysis

- Throughput level
- $O(1M)$ RHS-s/cfg



Throughput challenge

- Solvers still important
- Large problems / node -> minimize memory traffic
- Job coordination -> Grid based

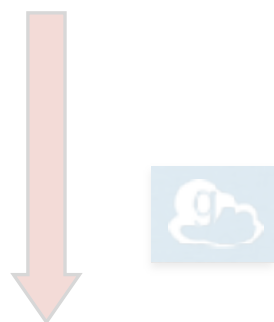

Contractions

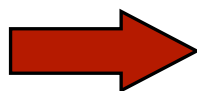

Correlators

- $O(1M)/\text{cfg}$

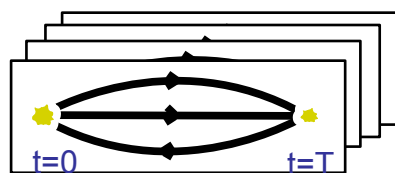

“Workflow” challenge

- Combinatorics -> improved graph theoretic methods
- Code generation for (sparse?) tensor contractions
- Job coordination -> Grid based

QCD for nuclei

- Quarks need to be tied together in all possible way

$$N_{\text{contractions}} = N_u!N_d!N_s! \quad (\sim 10^{1500} \text{ for } {}^{208}\text{Pb})$$

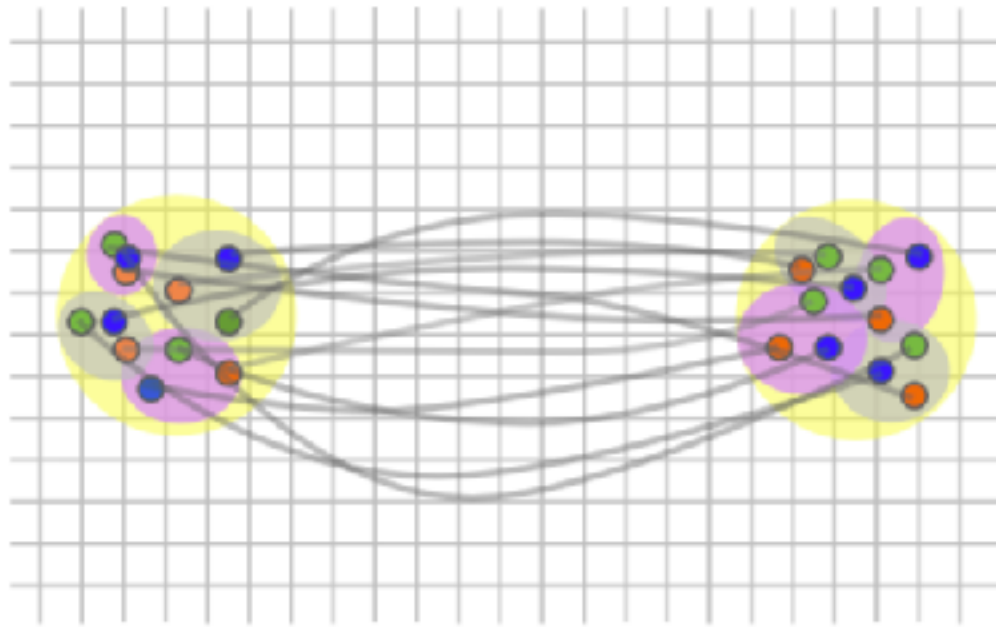

- Manage using algorithmic trickery - still significant graph contractions
- TACO @ MIT (cf TCE, Cyclops) <http://tensor-compiler.org>
 - general purpose tensor contraction compiler framework
 - target to QCD specific problems (sparsity patterns, ...)
 - Allow efficient exploration of methodology

Other activities

- Kokkos and KokkosKernels
 - Kokkos team & Siva Rajamanickam (Kernels)

- Autotuning
 - Useful in several physics stages: Petabricks

- Opentuner
 - USQCD software stack



SciDAC-4 is a partnership

- Strong existing partnerships with ASCR & HEP community members
- Developing stronger ties with SciDAC institutes
- Already a big boost for LQCD & NP
 - fresh perspective on entire program
- Is significantly impacting our calculations
 - huge advance in gauge generation - accelerated our science campaigns
 - workflows optimally use available resources - lower bar for new researchers
 - better tools for (more easily) improving performance



